

Job Name: \_\_\_\_\_

Type: \_\_\_\_\_

Part #: \_\_\_\_\_

Notes: \_\_\_\_\_

## LLKZXTEU THIN DIE-CAST ALUMINUM EXIT SIGN

STANDARD



### ILLUMINATION

- Ultra bright, energy efficient, long life Red or Green LEDs.

### ELECTRICAL

- Dual 120/277 voltage.
- Charge rate/power "ON" LED indicator light and push-to-test switch for mandated code compliance testing.
- 2.4V long life, maintenance-free, rechargeable NiCd battery (EM models only).
- Internal solid-state transfer switch automatically connects the internal battery to LED board for minimum 90-minute emergency illumination.
- Fully automatic solid-state, two rate charger initiates battery charging to recharge a discharged battery in 24 hours.

### MOUNTING

- Aluminum mounting canopy included for top or end mount.
- Universal knockout pattern on back plate for wall mount.

### HOUSING

- Premium-grade, aluminum housing (also available in optional black or white powder-coated finishes).
  - Field selectable knockout Chevron directional indicators.
  - Quick-snap face plate closure.
- Specification-grade, low profile, thin aluminum die-cast design.
- Available in single or double face only.



### WARRANTY / LISTING

- Five year warranty on all electronics and housing. Battery prorated for five years.
- Meets UL924, NFPA 101 Life Safety Code, NEC, OSHA, Local and State Codes.
- UL Listed for damp locations (0°C – 50°C).
- Certified to CEC under Title 20 Regulations.

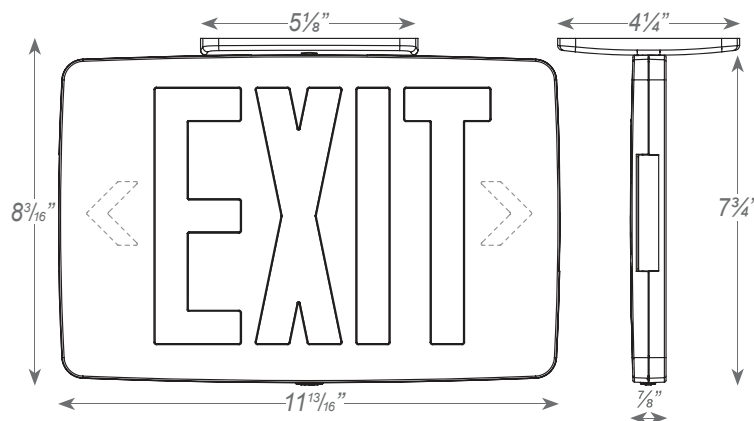

### ORDERING INFORMATION

Model	No. of Faces	Letter Color	Housing Color	Battery
LLKZXTEU	1-Single Face	R-Red	WHT-White	Blank- AC Only
	2- Double Face	G-Green	BLK-Black A- Aluminum	EM- Battery Backup

May be available with other voltage, wattage, finish, and cable length options by special order.  
Please contact your Lumencia Representative for more information.

Job Name: \_\_\_\_\_

Type: \_\_\_\_\_

Part #: \_\_\_\_\_

Notes: \_\_\_\_\_

### BG-1 Vandal Shield:

- High-impact resistant polycarbonate material.
- Mounting hardware provided for easy installation in the field.



BG-1

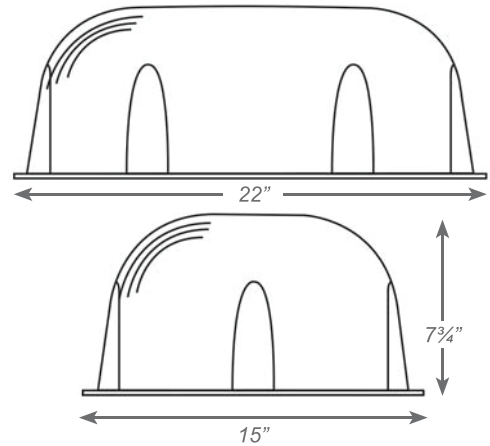

### PCS - 1 - Vandal Shields:



PCS-1

PCS-1

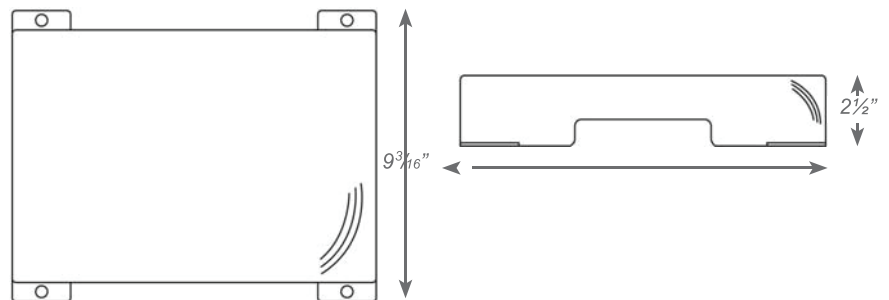

### WG-1 Wire Guard:

- Durable 9-gauge steel construction.
- Mounting hardware provided for easy field installation.



WG-1

